

f.a.l.

COMET 4000

Instruction Manual

model:

PF 570 COMET 4000

ATTENTION

This instruction manual contains important information about the installation and use of the projector. Please read and follow these instruction carefully.

ATTENTION



Always ensure that the power to the projector is disconnected before opening the projector or commencing any maintenance work.

INDEX

01 – SAFE USAGE OF THE PROJECTOR	3
02 – INSTALLING THE PROJECTOR.....	3
03 – FITTING THE LAMP.....	4
04 – POWER SUPPLY - MAINS.....	4
05 – CONTROLS	5
06 – REMOTE CONTROL.....	5
07 – MAINTENANCE	6
08 – KEEPING THE PROJECTOR CLEAN	6
09 – TROUBLESHOOTING.....	6
10 – ELECTRICAL DIAGRAM.....	7
11 – TECHNICAL SPECIFICATIONS.....	8

Please note that as part of F.A.L.'s ongoing commitment to continuous product development, specifications are subject to change without notice. Whilst every care is taken in the preparation of this manual F.A.L. reserves the right to change specifications in the course of product improvement. The publishers cannot be held responsible for the accuracy of the information herein, or any consequence arising from them.

01 – SAFE USAGE OF THE PROJECTOR

- ✓ Do not attempt to dismantle and modify the projector.
- ✓ Do not allow contact with water or any other fluids, or metallic objects.
- ✓ Do not install the projector in areas of high humidity.
- ✓  The projector is not designed or intended to be mounted directly on to inflammable surfaces.
- ✓ Keep at least 0.5m distance between the projector and adjacent inflammable surfaces.
- ✓ The projector must only be used complete with its protective grill and/or front lens.
- ✓ The protective grill, lenses or ultraviolet filter must be changed if they are visibly damaged to the point at which their effectiveness is diminished, for example by becoming cracked or deeply scratched.
- ✓ The lamp must be changed if it becomes damaged or deformed by heat.
- ✓ \varnothing 5 m  Keep at least 5m between the lamp and the illuminated surfaces.
- ✓ Avoid direct exposure to the light from the lamp. The light is harmful to the eye.
- ✓ Note: the lamp reaches very high temperatures, allow at least 15 minutes after switching off for the lamp to cool completely before attempting to handle it.
- ✓ To ensure the reliability of the projector it should be kept clean. It is recommended that the fans should be cleaned every 15 days. The lens and dichroic filters should also be regularly cleaned to maintain an optimum light output. In locations such as discotheques the objective lens should be cleaned every week as smoke fluid can condense on it and very quickly reduce the light output.

02 – INSTALLING THE PROJECTOR

The projector should be fixed with the 4 Z brackets (1) or with its 2 side stabilisers (2). These mounting systems are required so that the projector will not roll during operation. If the projector is to be fixed with the Z brackets, remove the wheels and into their position fix the Z brackets. Remove the transport bracket (3), by unscrewing the M6 screws (4). Connect the 10 pin plug (5) of the projector to the socket (6) on the power unit (ballast).

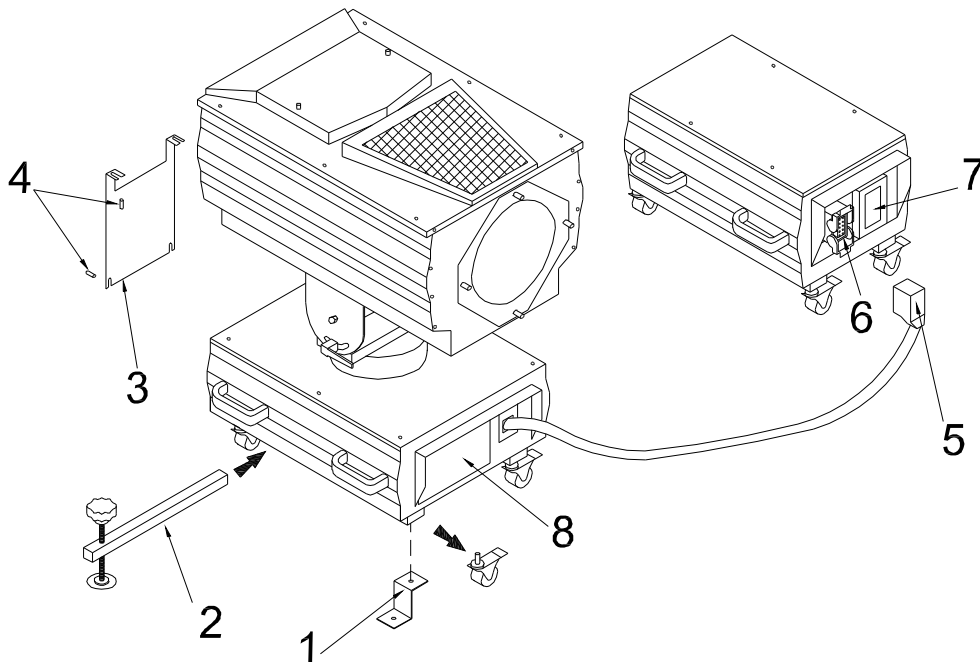

03 – FITTING THE LAMP

To open the lamp access hatch on the top of the projector undo the Allen screws (9) with a 6mm hexagonal Allen key. Insert the HMI 4000W/SE lamp into its socket (fig. A). The HMI 4000W/SE is a high pressure lamp with external igniter ⚠. Care should always be taken when handling these lamps (use a cloth). If the glass is accidentally touched, follow the manufacturers instructions for cleaning the lamp before you use it, otherwise the lamp life may be significantly reduced. Always read the manufacturers "Instructions for use" enclosed with the lamp.

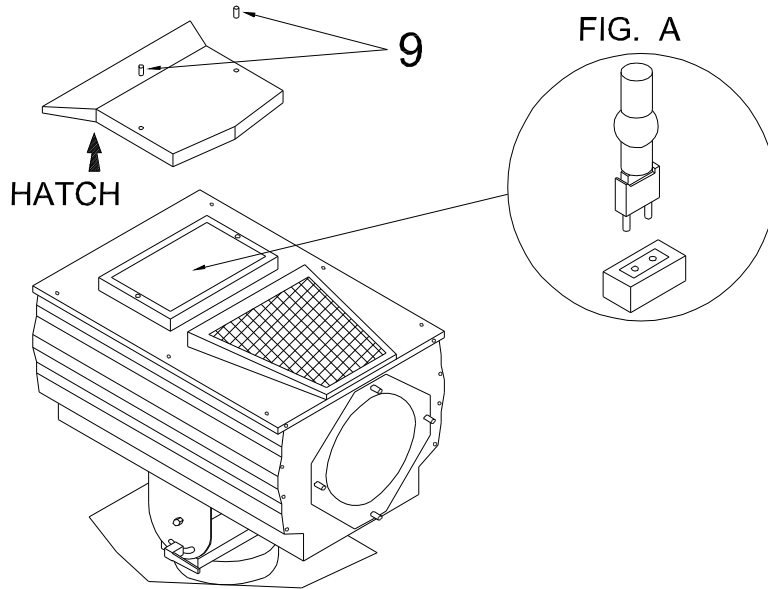

04 – POWER SUPPLY - MAINS

Use the plug (10) provided to connect the mains power to the projector paying attention to the voltage and frequency marked on the label attached to the projector and using a bi-phase power supply system. The projector can be operated from its own switch (7) on the ballast unit. Select one of the following phase combinations to power the projector:

PLUG PIN	PHASE		
1	R	T	R
E	YELLOW/GREEN		
2	S	S	T

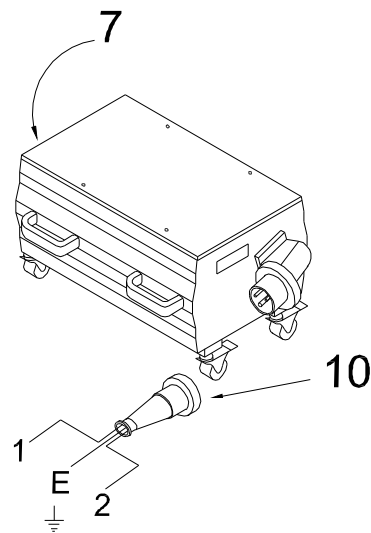

IMPORTANT

It is essential that each projector is correctly earthed and that electrical installation conforms to all relevant standards. Power consumption of the Comet 4000 is 5700VA.

05 – CONTROLS

Open the hatch (8) on the base of the projector to find the control panel.

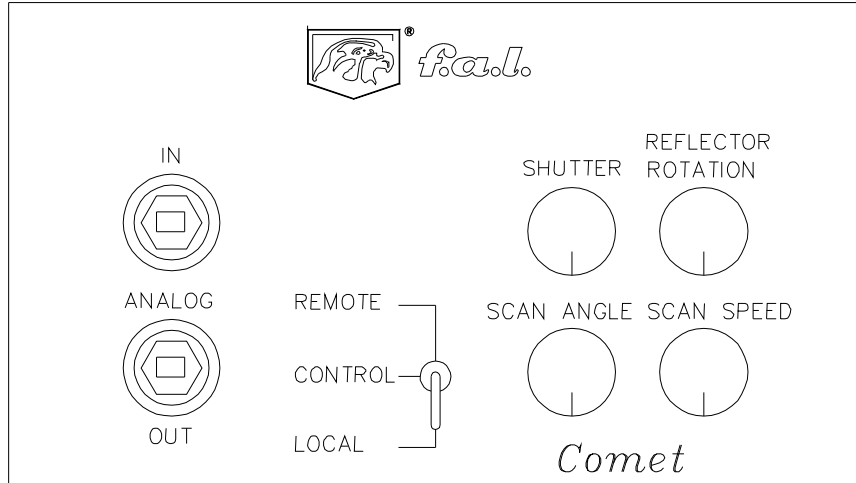

“CONTROL” SWITCH

The switch marked CONTROL decides the mode of functioning, local or remote. Set to LOCAL the Comet 4000 can be controlled directly from its own internal control panel.

SHUTTER

With this potentiometer you can control the opening and closing of the shutter. With the potentiometer at maximum (full clockwise) the shutter is open. With intermediate positions the shutter will produce a strobe effect at different speeds.

SCAN ANGLE

This function selects the angle of scan movement of the projector. The range is from 2° minimum (potentiometer full anti-clockwise), to 180° maximum (potentiometer full clockwise).

SCAN SPEED

To control the scan speed adjust the potentiometer. The range is from stopped, (potentiometer full anti-clockwise) to maximum speed (potentiometer full clockwise).

REFLECTOR ROTATION

This control determines the rotation speed of the internal mirrored parabolic reflector. The range is from stopped (full anti-clockwise), through different rotation speeds to the potentiometer at maximum clockwise where the reflector will change its direction of rotation each time the Comet 4000 changes its direction of scan movement.

06 – REMOTE CONTROL

Select the REMOTE option on the “control” switch and the projector will function from either a dedicated controller (PF 567) or from 4 Channels of 0-10V analogue DC control.

The channels assignment are as follows (channel function is the same as explained in the previous section):

- ✓ Channel 1 – Scan speed
- ✓ Channel 2 – Scan angle
- ✓ Channel 3 – Reflector rotation
- ✓ Channel 4 – Shutter

Connect the projector to the controller according to the following diagrams.

CONNECTIONS FOR REMOTE CONTROL

PF 567 CONTROLLER OUTPUT CONNECTOR

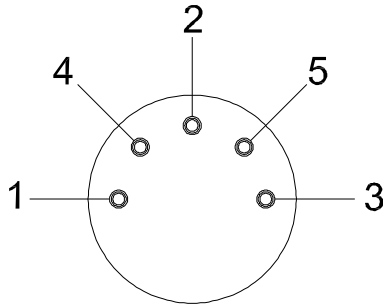

1. GND
2. Shutter
3. Speed for base motor
4. Rotation of internal reflector
5. Scan angle for base motor

COMET INPUT CONNECTOR

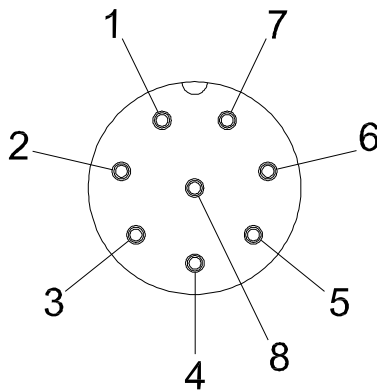

1. Speed for base motor
2. Scan angle for base motor
3. Rotation of internal reflector
4. Shutter
5. Reserved
6. Reserved
7. GND
8. + 15 Volts

07 – MAINTENANCE

If the protective plate or the lens becomes damaged or broken they should be replaced.

If the lamp becomes damaged or deformed in any way it must be replaced.

If the light from the lamp appears dim this would normally indicate that it is reaching the end of its life and it should be changed at once, old lamps run to the extremity of their life can explode.

On the electronics card (pcb) inside the projector are two fuse rated at 3.15A T (slow blow), should this be damaged call a qualified technician before replacement.

The Comet 4000 also has a thermal protection device that will switch off the projector in case of overheating, should this operate, check that the fans are not blocked, and if they are dirty clean them before switching on the projector again.

Check that the fans are operational, if not call a qualified technician.

08 – KEEPING THE PROJECTOR CLEAN

To ensure the reliability of the projector it should be kept clean. It is recommended that the fans should be cleaned every 15 days. The lenses should also be regularly cleaned to maintain an optimum light output. Do NOT use any type of solvent on the mirrors.

09 – TROUBLESHOOTING

PROBLEM	POSSIBLE SOLUTION
The projector does not start	Check the fuses on the pcb.
The projector only functions intermittently	Check the fans are working and not dirty.
The projected image appears to have a halo	Check the lamp is installed correctly (section 03).
The beam appears dim	The lamp may be at the end of its life and should be replaced. Check the optics are clean.

Any other maintenance should only be performed by a qualified person.

10 – ELECTRICAL DIAGRAM

POWER UNIT CONNECTIONS

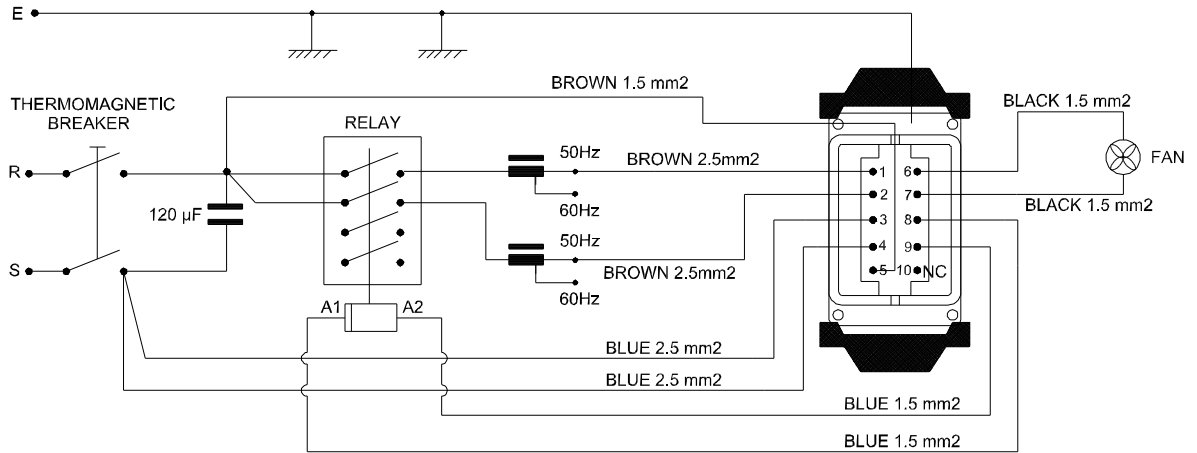

PROJECTOR CONNECTIONS

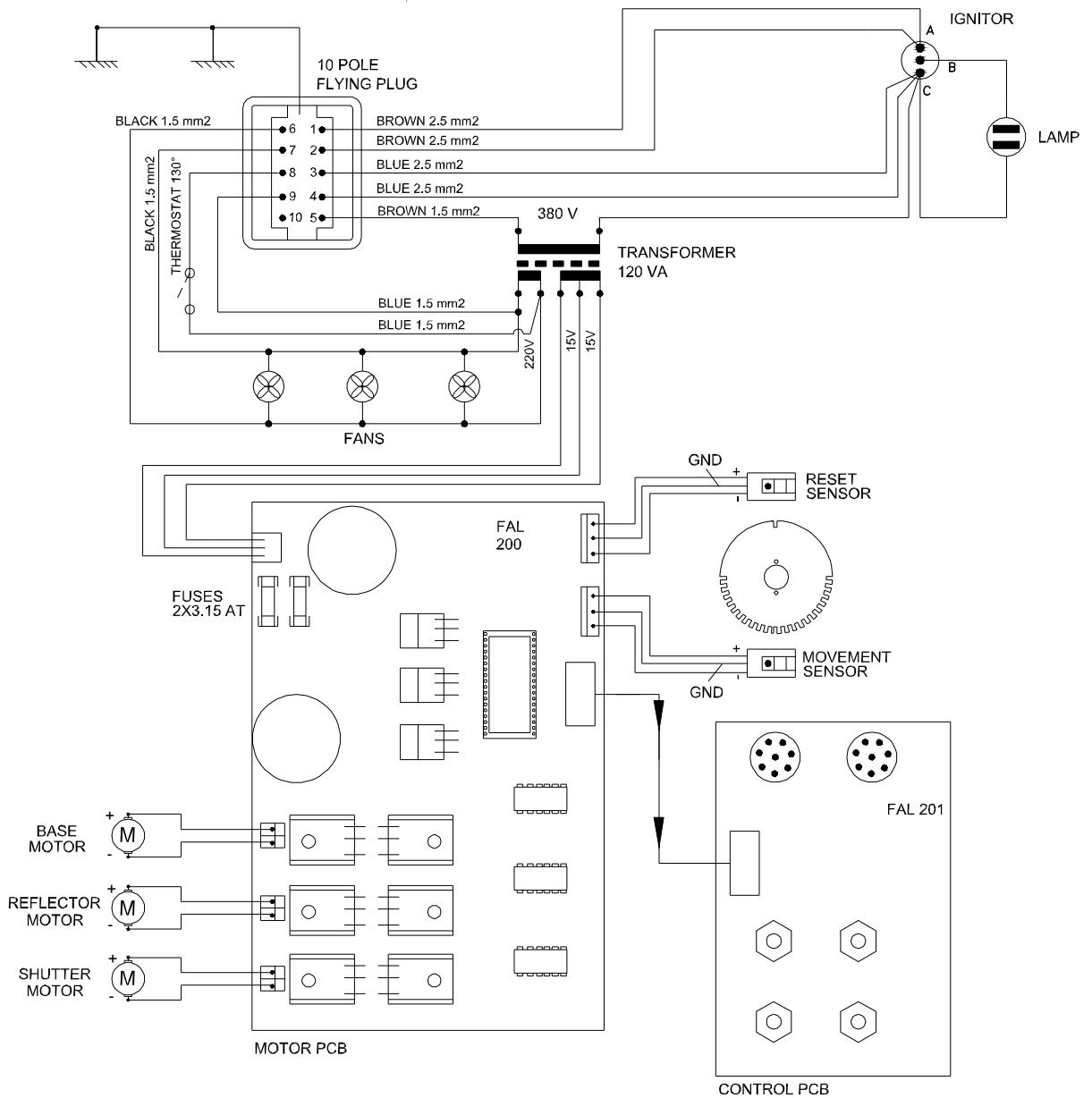

11 – TECHNICAL SPECIFICATIONS

POWER SUPPLY:	380V 50Hz or 60Hz bi-phase.				
POWER CONSUMPTION:	5700VA at 380V (with power factor correction).				
LAMP:	HMI 4000 SE metal halide discharge lamp. Colour temperature 6000K. Socket G38 life 500 hours (manufacturer ratings).				
COLOURS:	It is possible to install a colour filter.				
STROBE, SHUTTER:	Shutter for beam blackout also provides strobe effect.				
MOTORS:	3 DC motors controlled by the internal microprocessor.				
CONTROL:	Analog 0-10V DC - 4 channels. Dedicated controller PF 567.				
HOUSING:	Galvanised steel and extruded aluminium. Epoxy paint finish. Easy access to lamp and main components. Protection: IP33.				
DIMENSIONS:	<table> <tr> <td>Projector</td> <td>760mm L x 560mm W x 980mm H. Weight 60kg.</td> </tr> <tr> <td>External ballast</td> <td>650mm L x 400mm W x 350mm H. Weight 50kg.</td> </tr> </table>	Projector	760mm L x 560mm W x 980mm H. Weight 60kg.	External ballast	650mm L x 400mm W x 350mm H. Weight 50kg.
Projector	760mm L x 560mm W x 980mm H. Weight 60kg.				
External ballast	650mm L x 400mm W x 350mm H. Weight 50kg.				
REFERENCE NORM:	CE				

