

INSTRUCTION MANUAL

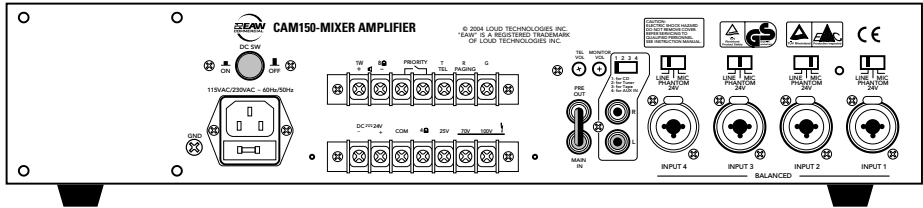

CAM150 / CAM60

Integrated Mixer/Amplifiers

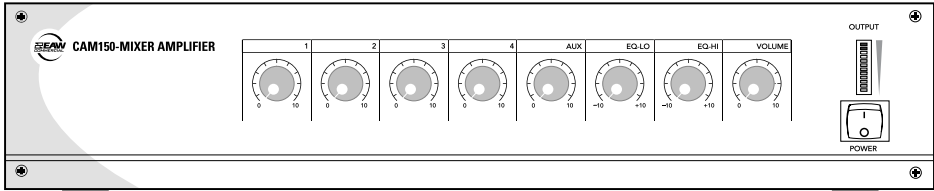

CAUTION AVIS

RISK OF ELECTRIC SHOCK • DO NOT OPEN
RISQUE DE CHOC ELECTRIQUE
NE PAS OUVRIR

CAUTION: TO REDUCE THE RISK OF ELECTRIC SHOCK
DO NOT REMOVE COVER (OR BACK)
NO USER-SERVICEABLE PARTS INSIDE
REFER SERVICING TO QUALIFIED PERSONNEL

ATTENTION: POUR EVITER LES RISQUES DE CHOC
ELECTRIQUE, NE PAS ENLEVER LE COUVERCLE. AUCUN
ENTRETIEN DE PIECES INTERIEURES PAR L'USAGER. CONFIER
L'ENTRETIEN AU PERSONNEL QUALIFIE.

AVIS: POUR EVITER LES RISQUES D'INCENDIE OU
D'ELECTROCUTION, N'EXPOSEZ PAS CET ARTICLE
A LA PLUIE OU A L'HUMIDITE



The lightning flash with arrowhead symbol within an equilateral triangle is intended to alert the user to the presence of uninsulated "dangerous voltage" within the product's enclosure, that may be of sufficient magnitude to constitute a risk of electric shock to persons.

Le symbole éclair avec point de flèche à l'intérieur d'un triangle équilatéral est utilisé pour alerter l'utilisateur de la présence à l'intérieur du coffret de "voltage dangereux" non isolé d'ampleur suffisante pour constituer un risque d'électrocution.



The exclamation point within an equilateral triangle is intended to alert the user of the presence of important operating and maintenance (servicing) instructions in the literature accompanying the appliance.

Le point d'exclamation à l'intérieur d'un triangle équilatéral est employé pour alerter les utilisateurs de la présence d'instructions importantes pour le fonctionnement et l'entretien (service) dans le livret d'instruction accompagnant l'appareil.

1. SAFETY INSTRUCTIONS

1. **Read Instructions** — Read all the safety and operation instructions before operating the Component.
2. **Retain Instructions** — The safety and operating instructions should be kept for future reference.
3. **HEED ALL WARNINGS** — Follow all warnings on the Component and in these operating instructions.
4. **FOLLOW ALL INSTRUCTIONS** — Follow all operating and other instructions.
5. **Water and Moisture** — Do not use the Component near water — for example, near a bathtub, washbowl, kitchen sink, laundry tub, in a wet basement, near a swimming pool, etc.
6. **Ventilation** — This Component should be situated so that its location or position does not interfere with its proper ventilation. For example, it should not be situated on a bed, sofa, rug, or similar surface that may block any ventilation openings, or placed in a built-in installation such as a bookcase or cabinet that may impede the flow of air through ventilation openings.
7. **Heat** — Locate the Component away from heat sources such as radiators, or other devices which produce heat.
8. **Power Sources** — Connect the Component to a power supply only of the type described in these operation instructions or as marked on the rear panel. If using an external DC power supply or battery pack, be sure the voltage corresponds to the range indicated on the rear panel, and that it is connected with the correct polarity.
9. **Power Cord Protection** — Route power supply cords so that they are not likely to be walked upon or pinched by items placed upon or against them, paying particular attention to cords at plugs, convenience receptacles, and the point where they exit the Component.
10. **Object and Liquid Entry** — Do not drop objects into or spill liquids into the inside of the Component.
11. **Damage Requiring Service** — The Component should be serviced only by qualified service personnel when:
 - A. The power-supply cord or the plug has been damaged; or
 - B. Objects have fallen, or liquid has spilled into the Component; or
 - C. The Component has been exposed to rain; or

D. The Component does not appear to operate normally or exhibits a marked change in performance; or

E. The Component has been dropped, or its chassis damaged.

12. **Servicing** — The user should not attempt to service the Component beyond those means described in this operating manual. All other servicing should be referred to the EAW Commercial Service Department.

13. **To prevent electric shock**, do not use this polarized plug with an extension cord, receptacle or other outlet unless the blades can be fully inserted to prevent blade exposure.

Pour prévenir les chocs électriques ne pas utiliser cette fiche polarisée avec un prolongateur, un prise de courant ou une autre sortie de courant, sauf si les lames peuvent être insérées à fond sans laisser aucune partie à découvert.

14. **Grounding or Polarization** — Precautions should be taken so that the grounding or polarization means of the DX-810 is not defeated.

15. This apparatus does not exceed the Class A/Class B (whichever is applicable) limits for radio noise emissions from digital apparatus as set out in the radio interference regulations of the Canadian Department of Communications.

ATTENTION — Le présent appareil numérique n'émet pas de bruits radioélectriques dépassant les limites applicables aux appareils numériques de class A/de class B (selon le cas) prescrites dans le règlement sur le brouillage radioélectrique édicté par les ministere des communications du Canada.

WARNING! This equipment has been designed to be installed by qualified professionals only! There are many factors to be considered when installing professional sound reinforcement systems, including mechanical and electrical considerations, as well as acoustic coverage and performance. EAW Commercial strongly recommends that this equipment be installed only by a professional sound installer or contractor.

TABLE OF CONTENTS

1. SAFETY INSTRUCTIONS	2
2. INTRODUCTION	3
KEY FEATURES	3
APPLICATIONS	3
3. FRONT PANEL FEATURES	4
4. REAR PANEL FEATURES	5
5. THERMAL CONSIDERATIONS	8
6. CONNECTIONS	8
7. TYPICAL HOOKUP DIAGRAM	9
8. SPECIFICATIONS	10
9. SERVICE INFORMATION	11
10. EAW COMMERCIAL WARRANTY	11

2. INTRODUCTION

The CAM150 and CAM60 Paging Amplifiers are designed for continuous duty in speech, music, paging and sound reinforcement applications in churches, schools, offices, arenas, hotel meeting rooms, convention centers, recreation facilities and other venues demanding high performance, flexible features and rugged dependability.

The CAM150 has a 150 watt power amplifier, and the CAM60 has 60 watts. Apart from this difference in power output, the two models are identical in details and operation.

Four combination mic/line inputs are actively balanced, with individual switchable sensitivity controls for line-level input, mic-level input, and mic-level input with 24 VDC phantom power.

Input 1 has voice-activated priority over Inputs 2-4 and the AUX Input. Inputs 1-4 have switch-activated priority over the Aux input. A Telephone Paging input is provided on a terminal strip, with a rear panel volume control, and has voice-activated priority over all the inputs. The voice-activated priority has an internal adjustable level control.

The stereo unbalanced RCA Aux inputs are internally summed to mono, and have an input sensitivity switch to optimize the input for a CD player, tuner, tape player, or other auxiliary input. A small speaker can be used to monitor the auxiliary music program, and its volume adjustment is provided with a small monitor trim control on the rear panel.

Output modes include 4 Ω constant impedance, and 25 V, 70 V, and 100 V constant voltage. The smart output stage is fully protected against permanent damage caused by overloading, shorts, and extreme temperatures. The CAM150 and CAM60 operate on either 115 or 230 VAC, 50/60Hz, supplied by a detachable IEC power cord. A voltage selector switch is accessible from the bottom panel. A rear panel terminal strip connection is provided for connecting an external 24 VDC backup battery, with a rear panel DC power switch.

An unbalanced signal processing loop is provided on the rear panel with RCA connectors.

The front panel provides level controls for each Mic/Line input, Aux, and Master volume, as well as Bass and Treble. An LED Meter indicates signal strength and output overload. The Bass and Treble controls provide up to 10 dB of boost or cut at 100 Hz and 10 kHz respectively.

KEY FEATURES

- Four Combination 1/4-inch/XLR Mic/Line Inputs
- One Stereo Auxiliary Input
- One Telephone Paging Input with Volume Trim Control
- CAM150: 150 watt rms, convection cooled
- CAM60: 60 watt rms, convection cooled
- 4 Ω – 25 V – 70 V – 100 V Outputs
- Discrete component power amplifier
- Switched 24V Phantom Power
- One Speaker Monitor Output with Volume Trim Control
- Signal Processing Loop
- Switchable 24 VDC Backup Power Input
- 2 RU Rack-Mounting Kit Included

APPLICATIONS

- Foreground/Background Music Systems
- Sound Reinforcement Systems
- Paging Systems
- Continuous-duty Applications

3. FRONT PANEL FEATURES

1. INPUT LEVEL

These controls allow you to individually adjust the volume level of each of the four balanced inputs, and the Aux input. We recommend that you turn down the level controls of any unused or little-used inputs.

2. EQ-LO

Turn this clockwise to boost the level of the low-frequency range below 100 Hz. Turn it counter-clockwise to cut the level. In the center position, there is no change in level. The maximum boost and cut is 10 dB at 100 Hz.

3. EQ-HI

Turn this clockwise to boost the level of the high-frequency range above 10 kHz. Turn it counter-clockwise to cut the level. In the center position, there is no change in level. The maximum boost and cut is 10 dB at 10 kHz.

4. MASTER VOLUME

Use this volume control to adjust the sound output level to your speakers. Adjust the master level and the input levels to average settings, not too high and not too low. For example, if you find you have to turn the master volume up high, then the input level controls might be set too low. If the master volume becomes loud after a small rotation, then the input level controls might be set too high.

5. LED METER

This meter shows the signal level reaching the input section of the main power amplifier.

The lower eight LEDs represent the area between -20 dB and 0 dB. Adjust the Master Volume to keep your output within these levels.

Make sure the top two LEDs are not lit, or the outgoing signal will clip and distort. Turn down the Master Volume level so the top two LEDs do not light.

6. POWER SWITCH

Use this switch to turn the unit on or off. The power is on when the top of the switch is pressed, and off when the bottom is pressed. Turn it off if you are not using the unit for long periods of time.

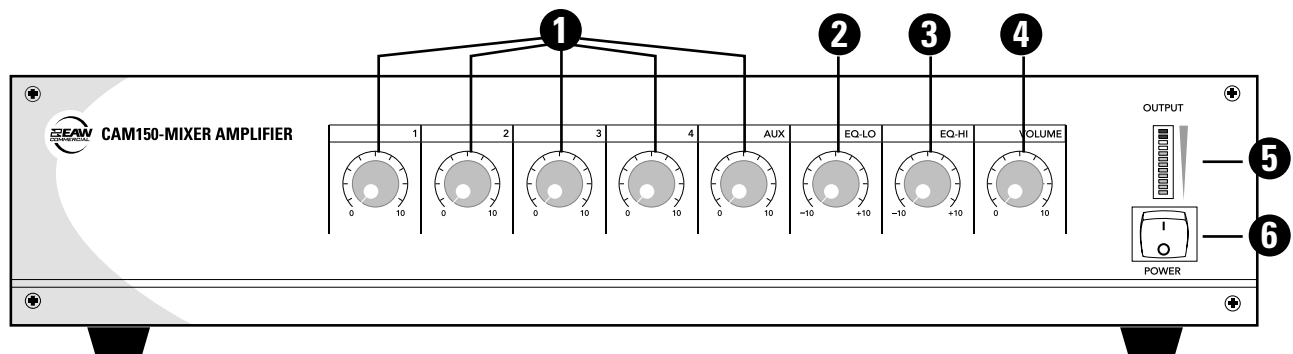

4. REAR PANEL FEATURES

7. DC POWER SWITCH

If this switch is pressed in, the unit will automatically switch to external DC battery power whenever (or if-ever) your local AC power fails. You will need to connect an external 24 Volt battery to the DC battery terminals (19).

If the switch is out, the battery will not power up the unit.

8. AUXILIARY SPEAKER TERMINALS

Use these terminals to connect a small speaker to monitor the AUX IN (16) Auxiliary input. The unit has an internal 1 watt amplifier to power the speaker, and you can control the volume with the rear panel MONITOR VOLUME (12) level control.

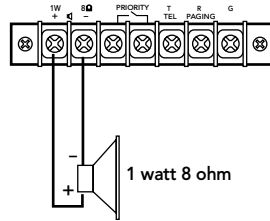

9. PRIORITY TERMINALS

If these terminals are connected together using an external switch, the AUX IN (16) input is attenuated and the other inputs have priority.

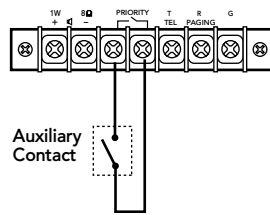

10. TELEPHONE PAGING TERMINALS

These 600 ohm input terminals allow you to connect an auxiliary input. Any signals present at these terminals take voice priority over all other inputs. The volume is adjusted using the rear panel TEL VOL (11) level control.

For a balanced connection:

- T = Tip (Hot or "+")
- R = Ring (Cold or "-")
- G = Ground (Shield)

For an unbalanced connection:

- T = Tip (Hot or "+")
- G = Ground (Shield)

11. TELEPHONE PAGING VOLUME

This controls the volume of any signals connected to the TELEPHONE PAGING (10) input terminals. Adjust it to suit your taste, so any pages are heard clearly. Turn this down if you are not using these input terminals.

12. MONITOR VOLUME

This control allows you to adjust the output level present at the AUXILIARY SPEAKER TERMINALS (8).

13. AUX IN INPUT SENSITIVITY SELECTOR

This four-position slide switch lets you adjust the input sensitivity of the AUX IN (16) to suit whatever source device you have connected. The options are: CD, Tuner, Tape, and Aux. Try each position, and find which sounds best.

14. INPUT SENSITIVITY and PHANTOM POWER SELECTORS

These three-position slide switches allow you to adjust each of the four inputs to suit whatever you are connecting. The positions are LINE, MIC and PHANTOM 24V.

LINE: select this if you are connecting a line-level signal.

MIC: use this if you are connecting a dynamic microphone.

PHANTOM 24V: use this if you are connecting a microphone which requires phantom power (such as condenser mics). The unit will supply 24 VDC on XLR inputs pin 2 and pin 3.

⚠ Consult your microphone's documentation to see if it needs phantom power. Take care as some microphones can be damaged. Also, never use phantom power if you have connected a line input using the XLR inputs. Do not plug or unplug any microphones with the phantom power on; turn it off first. Turn the front panel INPUT LEVEL controls down before you turn the phantom power on.

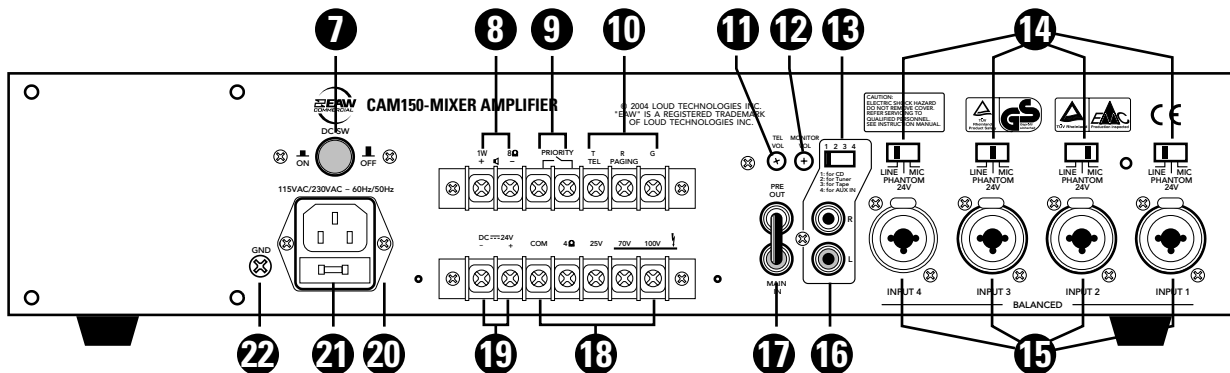

15. INPUTS

These inputs allow you to connect balanced XLR plugs from microphones or 1/4" TRS or TS plugs from line-level sources.

INPUT 1 has "Voice Priority" over the other inputs. If an announcement is made using a microphone connected to INPUT 1, then the other inputs are over-ridden.

16. AUX INPUTS

These left and right unbalanced RCA inputs allow you to connect your audio sources, such as tuner, CD player, DVD audio, tape deck, etc. They accept stereo line-level input signals, and sum them to mono. This input is suitable for connecting most common line-level sources. Use high-quality, two-conductor shielded cable for the connections.

17. MAIN IN, PREAMP OUT

These two connections are normally joined using a U-shaped jumper.

Note: If the U-shaped jumper is missing, then there will be no output from your unit.

Use the PREAMP OUT to send a line-level signal to an external amplifier, or to an external processor or equalizer. The output is affected by the Level controls, but not by the Master Volume or Tone controls.

The output from an external processor can connect to MAIN IN. The Master Volume and Tone controls will adjust any signals before they reach the main amplifier section.

18. OUTPUT TERMINALS

This terminal is normally covered by a protective cover. Remove the two screws and the cover while making or undoing connections. Securely refit the cover when you have finished making the connections.

The five output terminals are labeled COM, 4 Ω, 25 V, 70 V and 100 V.

CONSTANT IMPEDANCE

To connect a speaker directly, connect the COM terminal to the negative post of your speaker, and connect the 4 Ω terminal to the positive post.

! Make sure that your average speaker impedance is not less than 4 Ω, as this may overload the amplifier.

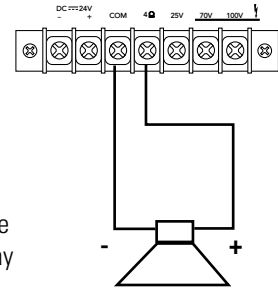

The speaker output connectors are screw terminals. Use 16 or 18 gauge wire for connecting the amplifier outputs to the speakers. Strip the wire back about 3/8" inch, loosen the screw enough to loop the wire around the shaft of the screw (clockwise), and tighten down the screw with a screwdriver.

CONSTANT VOLTAGE

If you are using a constant-voltage distributed speaker system, connect either the 25 V, 70 V, or 100 V output terminal to the "+" side of the speaker system, and connect the "COM" output terminal to the "-" side of the speaker system.

! The voltage of your speakers must equal the voltage of the amplifier's output terminal (25 V, 70 V, or 100 V).

Make sure that the taps on the speakers add up to no more than 90% of the rated power for the amplifier being used CAM150: 135 watts, CAM60: 54 watts.

! **CAUTION:** To prevent the risk of electric shock, never touch the bare wires coming from the OUTPUT TERMINALS of the amplifier when it is switched on. When the connections have been made, insulate the 25 V, 70 V, and 100 V terminals of the amplifier using the protective cover supplied.

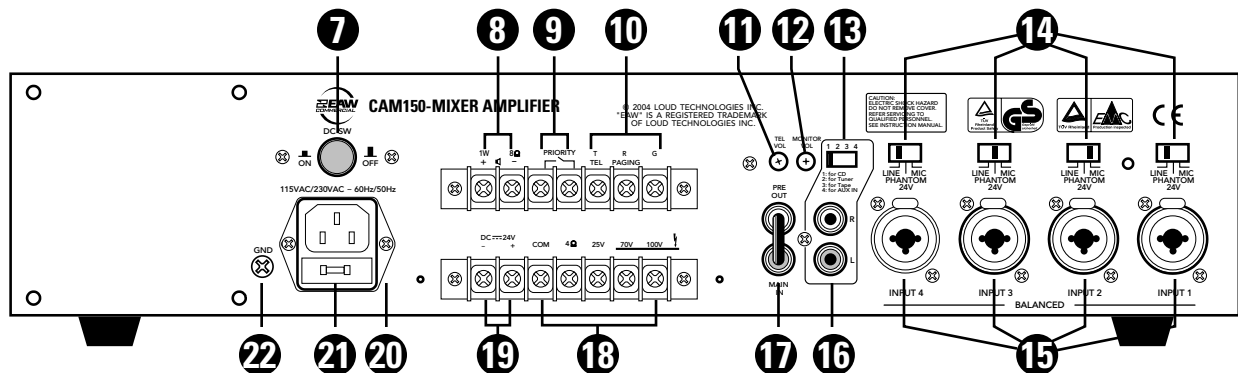

COM and 25V are used to connect a string of 25V speakers. Use Class II or Class I wiring:

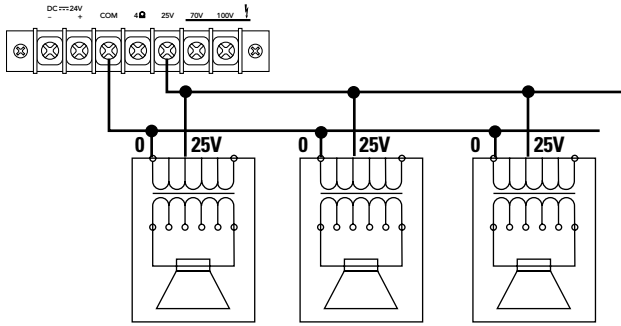

COM and 70V are used to connect 70V speakers. Use Class I wiring:

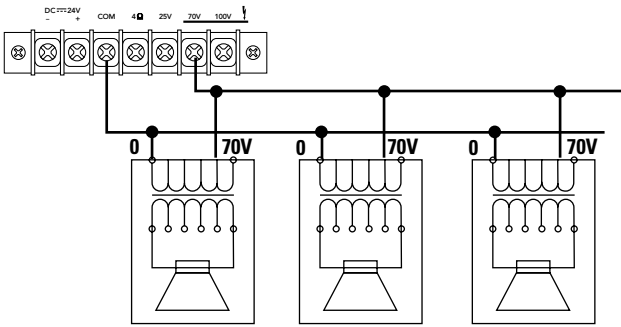

COM and 100V are used to connect 100V speakers. Use Class I wiring:

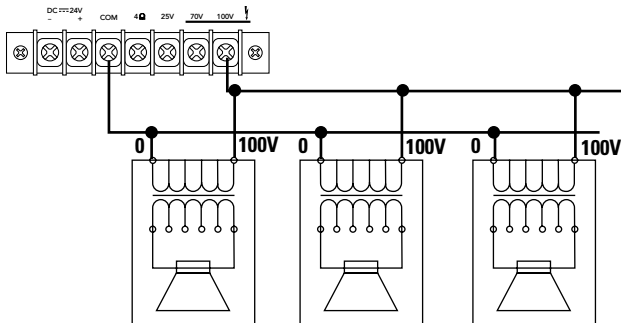

19. DC BATTERY TERMINALS

These two screw terminals are used to connect an optional external 24 VDC battery.

! Make absolutely sure the positive post of your battery connects to the positive terminal, and the negative post connects to the negative terminal. To minimize the voltage drop across the wires and prevent overheating, use at least 14 AWG insulated wire.

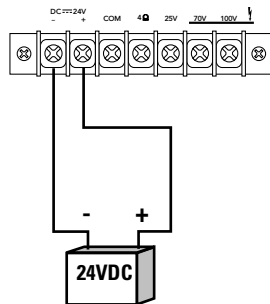

The unit can be powered using a 24 VDC power supply (if the rear panel DC POWER SWITCH is pressed in). This can serve as a backup supply in case of an AC power failure. The unit seamlessly switches to the backup supply if there's a power loss, allowing safety instructions and emergency communications to continue. When both AC power and 24 VDC power are connected, the AC power is used and no current is drawn from the DC supply.

Note: The unit will not charge the battery, so you should have a dedicated charging system. Note also, that when running on DC power, the output is lower than when running on AC power.

20. IEC AC INPUT

! The supplied power cord connects here. Make sure that your local AC Mains has the same voltage as your unit, and is capable of supplying adequate current.

Voltage Conversion

The CAM150 and CAM60 can be configured to operate at 115 VAC or 230 VAC.

! Be sure the VOLTAGE SELECTOR switch located on the bottom panel is set to the correct position for the AC power supply being used, before plugging in the power cord. The switch can be moved with a small flat screwdriver, once the protective cover is removed. Replace the cover afterwards.

21. AC FUSE

The fuse resides inside a little cover just below the AC input.

! Make sure that the power cord is unplugged before removing the AC fuse. When you are sure that all is safe, pry off the fuse cover with a flat screwdriver, taking care not to damage the cover or fuse. Replace the fuse only with the same type and rating as marked on your unit.

22. GROUND (EARTH) SCREW

The chassis connects to ground via the AC ground, and normally does not need any extra ground connection. Connections, if required, should be made by experienced, qualified electricians.

5. THERMAL CONSIDERATIONS

The power amplifier within the unit is convection cooled rather than fan cooled. Heat is drawn away from the amplifier by the heatsink and radiated through the cooling vents in the top cover.

! When installing, be sure to allow sufficient air space around the top and rear of the amplifier to allow adequate cooling for the heatsink. Leave at least one rack space above and below, and at least 6 inches behind the chassis to allow proper ventilation.

If the amplifier should overheat, a thermal switch turns off the power amplifier, allowing the heatsinks to cool down. Once the amplifier has cooled to a safe operating temperature, the thermal switch resets and reactivates the amplifier. If this should occur, identify the cause of the problem and take corrective action. For example:

- Provide better ventilation
- Install a fan in the rack to move more air
- Make sure the amplifier is not overloaded with too low of a load impedance or by a short circuit on the speaker line

RACK MOUNTING

Two rack ears are provided to allow the unit to be fitted within a standard 19" rack.

Remove two front screws from each side, and securely fit each rack ear in place. The unit still needs to be supported underneath, due to the weight of the power and output transformers.

6. CONNECTIONS

Inputs 1 to 4 use a dual-purpose input connector which can accept XLR and 1/4" TRS and TS plugs.

The AUX IN uses unbalanced RCA connectors, as does the MAIN IN and PREAMP OUT.

XLR Connectors

Inputs 1 to 4 can accept 3-pin male XLR connectors, wired as follows (according to standards specified by the Audio Engineering Society):

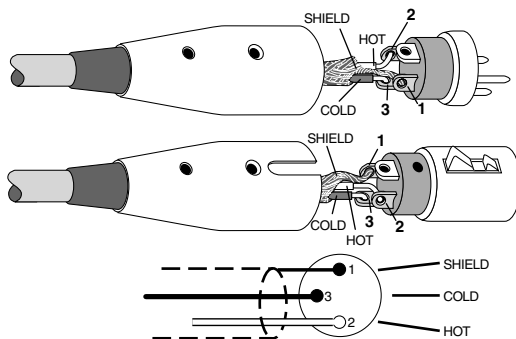

XLR Balanced Wiring

Pin 1 = Shield
Pin 2 = Hot (+)
Pin 3 = Cold (-)

1/4" TRS Phone Plugs and Jacks

"TRS" stands for Tip-Ring-Sleeve, the three connections available on a stereo 1/4" or balanced phone jack or plug. TRS jacks and plugs are used for balanced signals and stereo headphones.

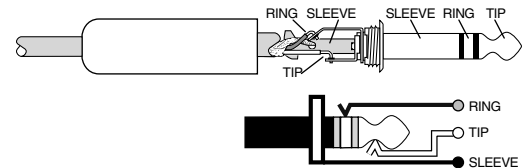

1/4" TRS Balanced Mono wiring

Sleeve = Shield
Tip = Hot (+)
Ring = Cold (-)

1/4" TS Phone Plugs and Jacks

"TS" stands for Tip-Sleeve, the two connections available on a mono 1/4" phone jack or plug. They are used for unbalanced signals.

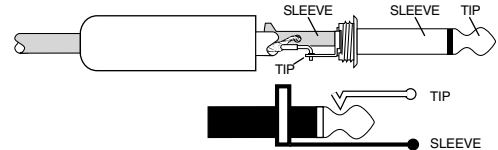

1/4" TS Unbalanced Wiring

Sleeve = Shield
Tip = Hot (+)

RCA Plugs and Jacks

RCA-type plugs (also known as phono plugs) and jacks are often used in home stereo and video equipment and in many other applications. They are unbalanced and electrically equivalent to a 1/4" TS phone plug.



RCA Unbalanced Wiring

Sleeve = Shield
Tip = Hot

7. TYPICAL HOOKUP DIAGRAM

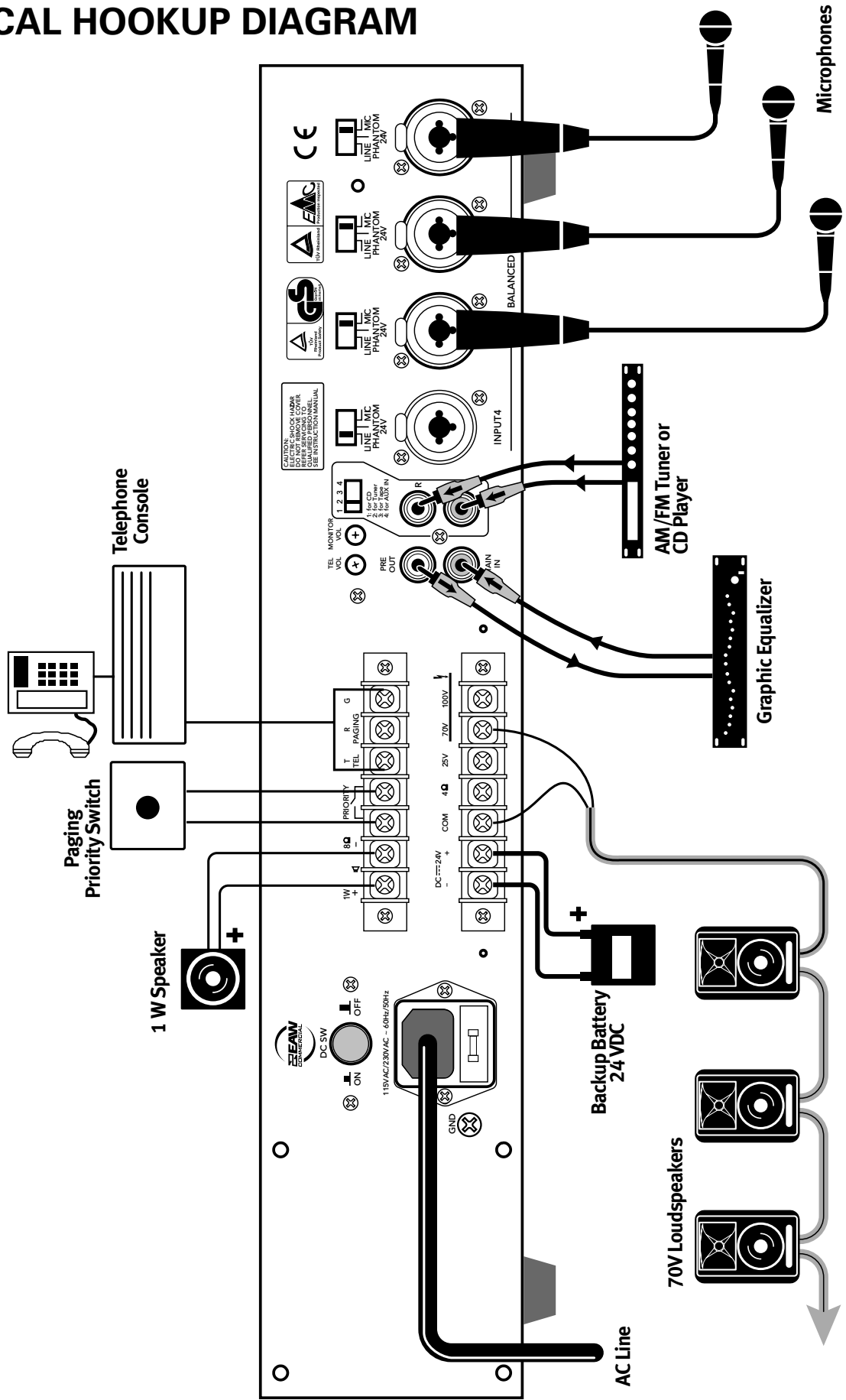

8. SPECIFICATIONS

Performance

CAM150 Amplifier Power:	150 W, nominal, 200 W peak (10 mS)
CAM60 Amplifier Power:	60 W, nominal, 90 W peak (10 mS)
Frequency Response:	50 Hz–15 kHz ± 3 dB
Distortion:	< 0.5% THD at 1 kHz nominal power
Noise:	>60 dB below nominal power

Equalization

Output:	EQ-HI: ± 10 dB at 10 kHz
	EQ-LO: ± 10 dB at 100 Hz

Audio Inputs

Inputs 1-4 Type:	Four balanced/unbalanced combination 1/4-inch/XLR connectors with switchable input level and 24 VDC phantom power
Inputs 1-4 Mic Sensitivity:	-66 dBV balanced/-60 dBV unbalanced (0.5/1.0 mV)
Inputs 1-4 Line Sensitivity:	-26 dBV balanced/-20 dBV unbalanced (50/200 mV)
Inputs 1-4 Mic Impedance:	600 Ω
Inputs 1-4 Line Impedance:	47 k Ω
Aux In Type:	One pair unbalanced stereo RCA connectors
Aux In Sensitivity:	
CD:	-5 dBV (570 mV)
TUNER:	-15 dBV (180 mV)
TAPE:	-10 dBV (320 mV)
AUX:	-20 dBV (100 mV)
Aux In Impedance:	
CD:	80 k Ω
TUNER:	30 k Ω
TAPE:	50 k Ω
AUX:	20 k Ω
Tel/Paging Input Type:	One balanced/unbalanced screw-terminal connector with adjustable input level
Tel/Paging Input Impedance:	600 Ω
Main Input Type:	One unbalanced RCA connector
Main Input Sensitivity:	0 dBV (1 V)
Main Input Impedance:	10 k Ω

Audio Outputs

Number of Channels:	One
Low Impedance:	4 Ω
Constant Voltage:	25V, 70V, 100V Screw-terminal connectors CAM150 (4.5 Ω , 32.5 Ω , 66.5 Ω) CAM60 (10 Ω , 83 Ω , 170 Ω)
Pre Out:	One unbalanced RCA line-level output 1V/600 Ω
Monitor Out:	One terminal strip connection 1 watt/8 Ω

Control Inputs and Outputs

Inputs:	Priority switch input, dry contact closure Screw-terminal connectors
---------	---

Controls

Front Panel:	Power switch, Master Volume, Inputs 1-4, Aux level, EQ-HI (Treble shelving), EQ-LO (Bass shelving)
Rear Panel:	Telephone output volume level, Input 1-4 Mic/Line/Phantom switch, Monitor output volume level, 24 VDC on/off switch

AC Power

Power Supply:	115/230 VAC ($\pm 5\%$), 50/60 Hz, 2.5 A fuse
24 VDC battery:	CAM150: 15 A fuse CAM60: 8 A fuse
Power Consumption:	CAM150: 345 W CAM60: 132 W

Environment

Maximum Ambient:	131° F (55° C) Non-precipitating humidity
------------------	---

Physical

Dimensions (HxWxD):	3.9 in/100 mm x 17.1 in/435 mm x 13.2 in/335 mm
Weight:	CAM150: 25.6 lb/11.6 kg CAM60: 22.3 lb/10.1 kg

Warranty

5 years, parts and labor

Accessories

Rack-mount kit

DISCLAIMER

EAW Commercial continually engages in research related to product improvement, new materials, and production methods. Design refinements are introduced into existing products without notice as a routine expression of that philosophy. For this reason, any current EAW Commercial product may differ in some respect from its published description, but will always equal or exceed the original design specifications unless otherwise stated.

“EAW Commercial” is a trademark of LOUD Technologies Inc. All other brand names mentioned are trademarks or registered trademarks of their respective holders, and are hereby acknowledged.

VOICE PRIORITY ADJUSTMENT

The amplifier has an internal adjustment potentiometer (on the front circuit board) which allows you to set the level at which the voice priority circuit activates.

For example, suppose that only **loud** talking into a paging microphone (on Input 1) will mute the auxilliary music. This pot can adjust the voice priority sensitivity until it takes only moderate or low volumes to mute the aux music.



Please note that the following adjustment requires that the top cover be removed, therefore this procedure is for qualified and experienced electronics technicians only, carefully trained in all aspects of ESD (electro-static discharge) precautions and electronics safety.

1. Make sure the unit is switched off, and that the power supply cord and all other cords are removed.
2. Undo the top cover screws and remove the top cover.
3. Look at the top edge of the front panel circuit board. Just above the INPUT 2 Level control, you will see a small potentiometer, VR102.

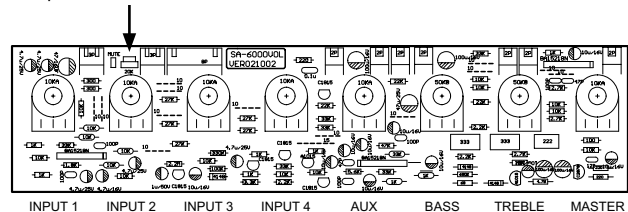

4. Using an insulated small phillips screwdriver, gently rotate this pot to change the sensitivity (clockwise for more sensitivity, i.e., less intense signals will mute the aux. The pot can be reached from the top by passing the screwdriver between the front panel top edge and the metal chassis.
5. The voice priority can also be disabled by removing the small jumper next to the pot. You will need a good pair of needle-nosed pliers, or remove the front panel circuit board from the front panel by pulling off all the plastic knobs and undoing the hex nuts on each level control.
6. When finished, recheck your work, and replace the top cover. Verify that Input 1 or the Telephone paging suitably mute the Aux and other inputs, without having to shout.

9. SERVICE INFORMATION

In the event that your CAM150 or CAM60 should require servicing, please follow these instructions:

1. Call EAW Commercial Tech Support at 1-888-337-7404, 7 am to 5 pm PST (Monday-Friday), to verify the problem and obtain a Return Authorization (RA) Number. Be sure to have the serial number of the unit when you call. You must have a Return Authorization Number in order to obtain warranty service at the factory or at an authorized service center. You can also email EAW Commercial Tech Support at: support@eawcommercial.com
2. Pack the unit in its original packaging. THIS IS VERY IMPORTANT. EAW Commercial is not responsible for any damage that occurs during shipping due to non-conventional packaging. Original packaging helps to minimize the possibility of shipping damage.
3. Include a legible note stating your name, (no P.O. boxes), daytime phone number, Return Authorization Number, and a detailed description of the problem, including how we can duplicate it.
4. Write the Return Authorization Number in BIG BOLD PRINT on the top of the box.
5. Tech Support will tell you where to ship the unit when you call for an RA Number. We suggest insurance for all forms of cartage.

BLOCK DIAGRAM

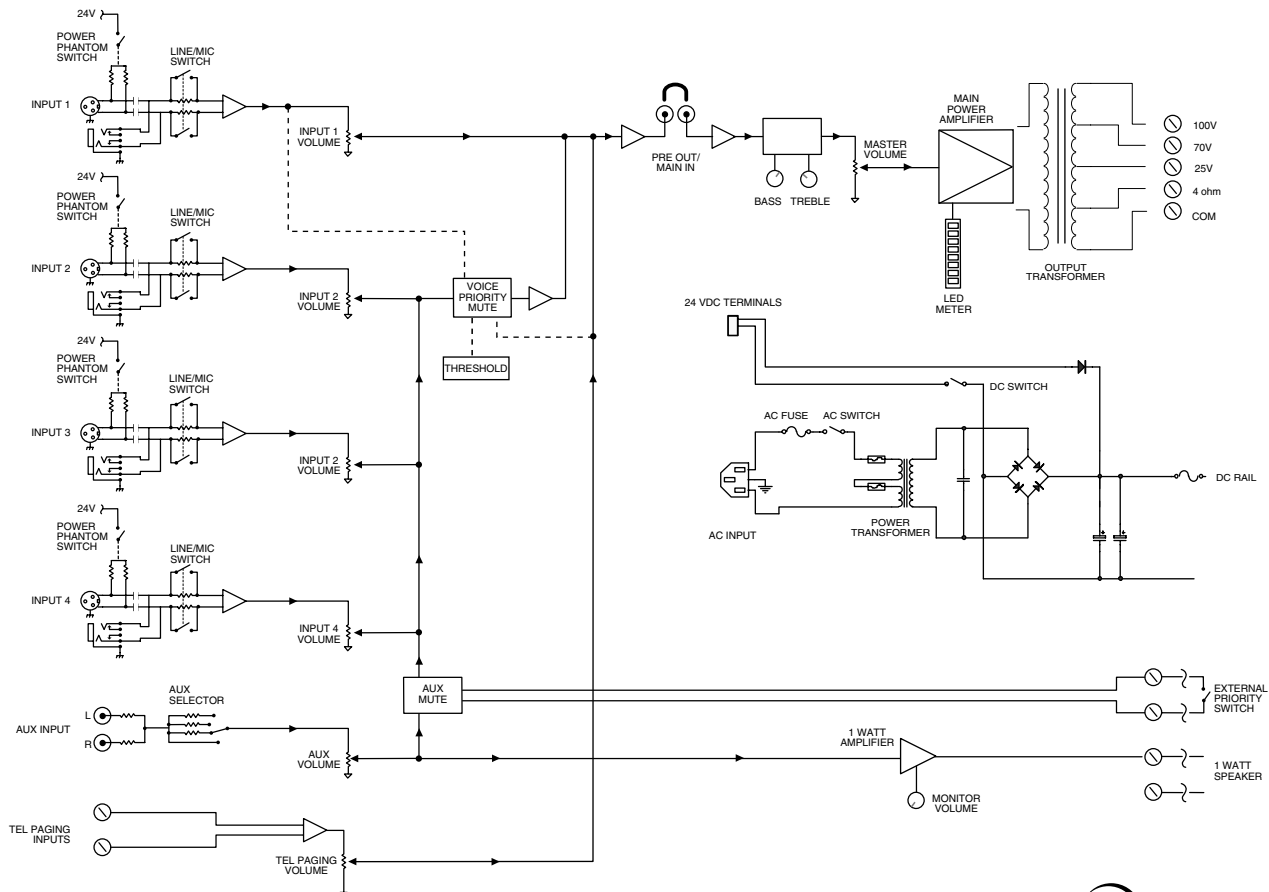

10. EAW COMMERCIAL WARRANTY

Warranty: LOUD Technologies Inc. requires its authorized EAW Commercial distributors to abide by the following warranty terms for all EAW Commercial brand products (all dates are from the date of delivery from an Authorized EAW Commercial Distributor to the end user/installation site): Loudspeakers – 5 years; Active Electronics – 5 years; Accessories – 2 years.

What Is Covered: Defects in workmanship and materials and against malfunctions. EAW Commercial distributors must remedy all such defects and malfunctions without charge for parts or labor if the warranty applies. Final determination of warranty coverage lies solely with each authorized EAW Commercial distributor.

What Is Not Covered: This warranty does not extend to damage or malfunctions resulting from, but not limited to, shipment, improper installation, misuse, neglect, abuse, normal wear, accident, or to any product on which the serial number has been modified or removed. Exterior defects in or damage to the exterior appearance are specifically excluded from this warranty. EAW Commercial distributors shall not be liable for incidental or consequential damages resulting from the use of EAW Commercial products. Repairs and/or modifications by other than an Authorized EAW Commercial Distributor automatically voids this warranty.



EAW Commercial A LOUD Technologies Inc. Company

EAW Commercial | One Main Street | Whitinsville, MA 01588 USA | TEL toll free within US/Canada 888.337.7404
TEL outside US 425.892.6503 | FAX 425.485.1152 | www.eawcommercial.com

© 2004 LOUD Technologies Inc. All Rights Reserved.