

Read this manual carefully and understand all of  
it's contents before you assemble and load the  
H30V Rigging Tower



# **PROLYTE ASSEMBLY MANUAL H30V RIGGING TOWER**

Version 2, July 2005



**PROLYTE PRODUCTS**  
STAGING - RIGGING - TRUSSING

Industriepark 9, 9351 PA Leek, The Netherlands  
phone: +31 (0)594 85 15 15, fax: +31 (0)594 85 15 16  
e-mail: [info@prolyte.com](mailto:info@prolyte.com), website: [www.prolyte.com](http://www.prolyte.com)

**RT-H30V Assembly instructions**

**CONTENTS**

1	System Description .....	3
2	Limitations of use .....	3
3	Scope of use .....	3
4	Identification, Parts .....	4
5	Dimensions & loading .....	6
6	General information .....	6
7	Assembly instructions .....	8
8	System Dimensions .....	13

## RT-H30V Assembly instructions

### 1. SYSTEM DESCRIPTION

The Prolyte H30V Rigging Tower is a lifting tool where the load is constrained by a horizontal and vertical V-shaped truss frame. The H30V Rigging Tower has a loading capacity that is limited by the construction. In general rigging towers are used where the lifting of loads from a building structure is impossible, very expensive, or when traditional telescopic winch stands do not have a sufficient load capacity, or when a Tower does not fit the purposes. The H30V rigging tower is used with a vertical mast of standardized H30V truss as compression absorbing elements, H30V truss as outriggers and a 60 mm tube as stabilizer brace.

### 2. LIMITATIONS OF USE

The H30V Rigging Tower is to be used with Prolyte trusses only. Loads to the trusses and towers shall be vertical only, **no side loading is allowed to the system, with an exception for wind loads.** The system may be used up to wind force 8 maximum.

The H30V Rigging Tower is designed as temporary lifting structure for in- and outdoor use.

When horizontal loading is applied, other than wind forces, appropriate measures, such as placing guy-wires (cable-stays) and ballast, have to be taken to ensure stability.

The H30V Rigging Tower is to be built by competent and trained persons only. For all other applications contact your local dealer or Prolyte.

### 3. SCOPE OF USE

Prolyte H30V Rigging Towers are designed for the lifting of speaker clusters or audience lights over stages, dance floors, exhibition area's, public area's, parking lots, etc.

H30V rigging towers are to be built to a maximum height of 7,5m (7 metre mast length).

## WARNING

Prolyte H30V Rigging Towers are not designed to lift people!

**RT-H30V Assembly instructions**

**4. IDENTIFICATION**

The H30V Rigging Tower (RT-H30V) is composed of the following parts:

	<b>Description</b>	<b>Code</b>	<b>weight</b>	<b>remarks</b>
1, 2	Tower trusses	H30V	5.1kg/m1	Max. height 7 m
3	Square H30V 3-way corner 60°	RT-H30V-C003	12.2kg	V-shaped corner block
4	Layher spindel attachment	ACC-Spin-ATT-30	2 kg	Pipe with trussclamps to adapt Screwjacks
5	Layher spindel, 40cm long	ACC-Spin-LAY-40	12 kg	Hot dip zinc plated screwjack, 20cm adjustable
6	Hinge part square truss	CCS6-H	0.58kg	
7	Topblock rigging tower H30V	RT-009H-2	12,2kg	Top section with removeable 30mm spigot
8	Stabelizer attachment H30V	RT-STAB-H30V	2,7kg	Frame with clamps to attach bracing to trusses
9	Stabelizer attachment H30V	RT-STAB-H30V-TOP	6,4kg	Frame with side-entry clamps to attach bracing
10	Stabelizer tube 60x5 mm	RT-T60-CC298CC	8kg	Stabelizer tube with conical CCS7 couplers
11	Conical Coupler	CCS6-600	0.14kg	
12	Spigot	CCS6-603	0.04kg	
13	Safety R-spring	CCS6-605	0.01kg	
14	Spigot	CCS7-703	0.11kg	
15	Safety R-spring	CCS7-705	0.01kg	

The embossed ring on the ends of the conical coupler receivers, and stickers featuring the Prolyte logo can clearly identify the trusses other rigging tower parts.

**WARNING**

Make sure the system is built only of genuine Prolyte components, which are clearly and positively identified as Prolyte products. Copies do exist, and even though they may appear to fit to Prolyte trusses, they do not have identical strength and safety characteristics.

**RT-H30V Assembly instructions**

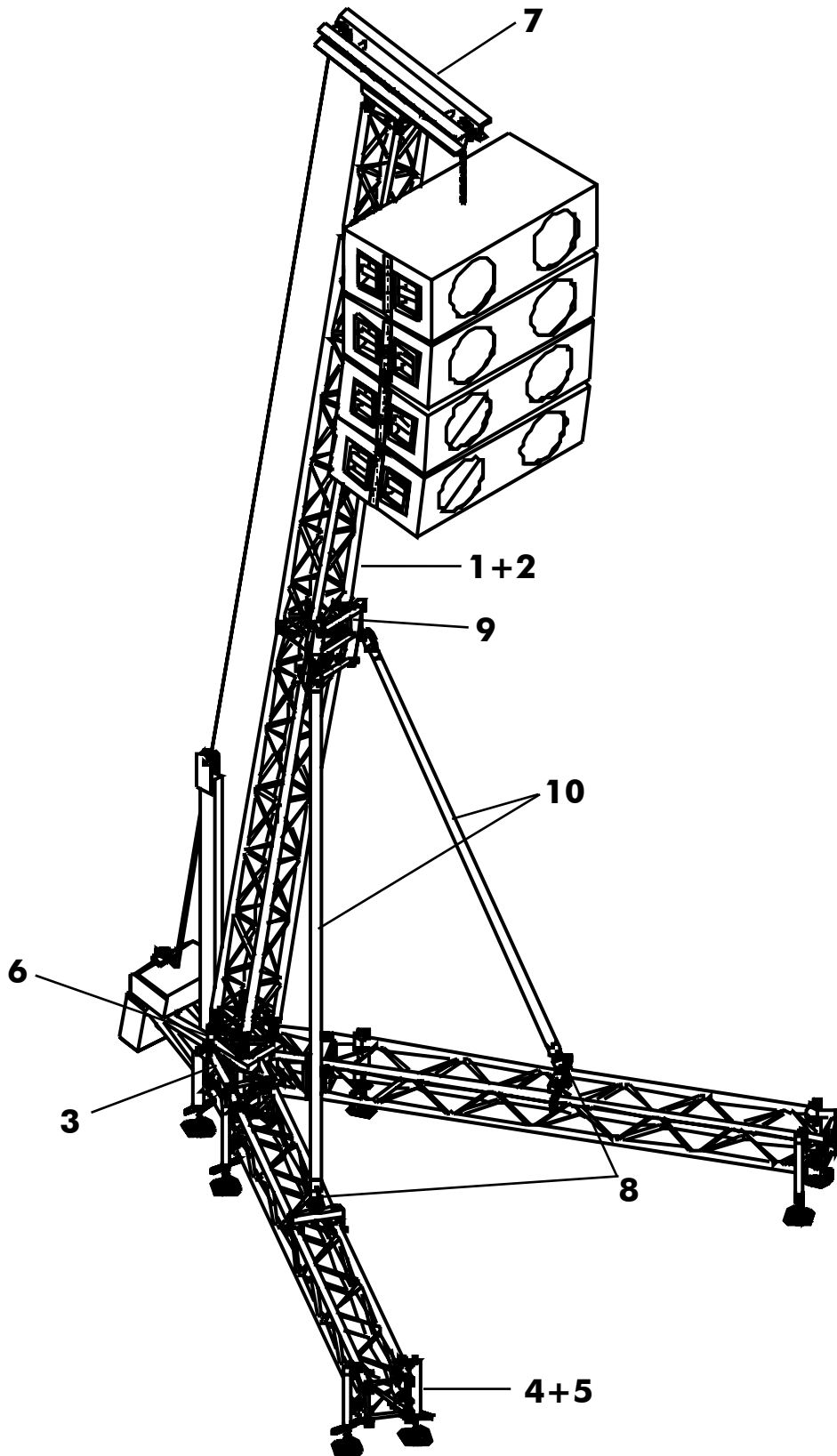

## RT-H30V Assembly instructions

### 5. DIMENSIONS & LOADING

#### WARNING

Payloads are to be vertical only at all times. Side loads are NOT permitted.

**The maximum allowable height** of a complete H30V Rigging Tower shall be no more than 7,5 m, including spindles and top-section.

**The maximum allowable load** to a H30V rigging tower of 7 m is:

Outdoor (max. wind force 8) : 550 kg

Indoor (no wind) : 700 kg

The max. load relates to the height of the tower.

Please consult our engineering department if you want to deviate from the given values.

#### Loading dimensions:

The total surface of the load may not exceed 2,5 m<sup>2</sup> at the front, and max. 1,25 m<sup>2</sup> at the sides.

#### The amount of Ballast that should be applied is:

Outdoor (max. wind force 8) : 100 kg per leg

Indoor (no wind) : no ballast needed

The necessary amount of ballast relates to the height of the tower, applied load and load surface.

Please consult our engineering department if you want to deviate from the given values.

The surface area per H30V rigging tower base is approximate 3.80x 3.80m

### 6. GENERAL INFORMATION

#### NOTE

Make sure only one competent person is chosen to be responsible for and in charge of all coordinating actions and supervising the entire building, erecting and dismantling process.

#### WARNING

Even if local legislation might be lacking any demands on personal safety, it is strongly advised to use fall protection-equipment when climbing the system during building, particularly at over 2m high from ground level, when falling hazards are prominent.

- 1) First identify all separate components and types of Prolyte truss to be used, ensure that you are fully conversant with this manual before you start using any of these parts, components and trusses!
- 2) Never use trusses, parts or vital components such as wire ropes (or chains), that show visual damage, deformation, wear & tear or have any other reason to doubt the safe functioning within the system. Make sure to check each item before each time of use.
- 3) Make sure that the system is built on solid ground. In situations where it has to be built on grass, sand or any unstable subsoil, under fill the screw jacks with plywood pads of 300x300x20mm (minimum size for each screw jack).

## RT-H30V Assembly instructions

### WARNING

The ground pressure on the screw jacks underneath a tower can easily be more than 0,95 ton with dead load, live load, wind load and full ballast imposed!  
Never erect the tower when any doubt remains on the safety of the underlying ground.

- 4) Check the building site for obvious hazardous objects such as power lines. Keep a safe distance of at least 8m from those in any possible direction of sway in the wind, or the distance as specified in the national or local codes or regulations for safe operation of mobile cranes. Always check the planned tower-building activity with the power-company.
- 5) Check the building site for obstacles such as lamp-posts, trees or tree-tops, overhead piping, in house constructions, or any other higher objects that might hamper erection of the towers or might endanger it when swaying in the wind or so.
- 6) Check local authorities for possible risks in subsoil, such as low stability peat or bog fillings, sewer or large drainage pipes, waterlogged soils in slopes etc.
- 7) Measure the area where the tower needs to be and make sure there is enough room for all components including the outriggers with the plywood padding (the free and cleared building site for each tower, needs to be app. 4 m wide, 7.5m deep and 8m high).<sup>(1)</sup>
- 8) The complete tower should be totally level when built. If the tower is not exactly level this may result in constructive weakness of the system.
- 9) Avoid dynamic loads. Do not turn the hoist on and off when hoisting the load in place. Lift the load as steady as possible.
- 10) Make sure the load can not turn once hoisted in place. Use tag-lines if needed which should be attached to the tower and NOT to the truss legs or the corner section.
- 11) Make sure the screw jack bracing attachments are placed correctly in alignment to the geometry of the truss sections.

<sup>1</sup> Except in the situations of hazardous objects or obstacles as mentioned above.

**RT-H30V Assembly instructions**

**7. ASSEMBLY INSTRUCTIONS**

**WARNING**

Inspect all components before using them on visual wear & tear, deformation, damage or any other shortcomings. NEVER use parts or component that are not visually correct or you suspect have been subject to other damage.

Always make sure that the floor or subsoil is sufficiently capable of carrying the load of the tower as it is transferred through the screw jack dishes. Use plywood panels or similar material to increase bearing capacity if needed. When in doubt check with a competent person.

**1** Assemble and connect the corner (RT-H30V-C003), the legs (H30V-L300) and the screwjacks (ACC-SPIN-ATT-30 + ACC-SPIN-LAY/40). See figures 1+2.

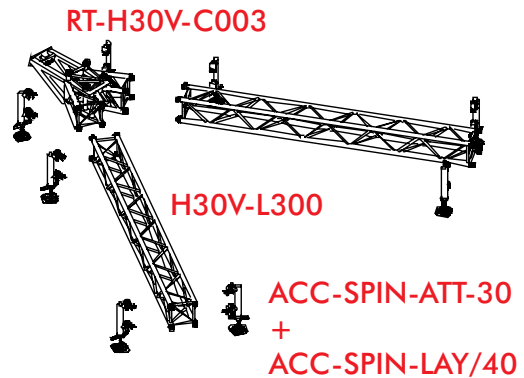

figure 1

**2** Level the V-shaped base, starting with the corner. Adjust the screwjacks as far as necessary, but no more than 100mm. For bigger height differences use woodpads. Work from the left to the right.

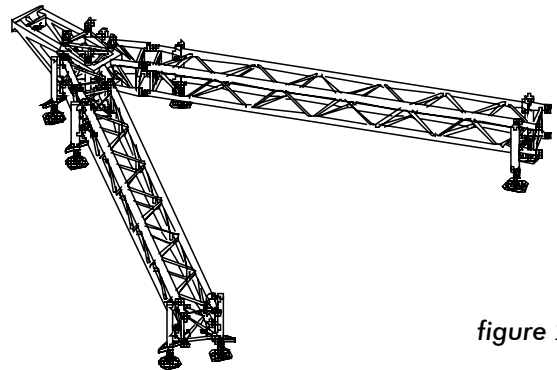

figure 2

**3** Unscrew the intermediate screwjacks until their footplates rest on the ground.

Place the hinge-parts (CCS6-H) as shown in figure 3, to facilitate the erection of the mast. Mount the other half of the hinge-parts in a similar way to the bottom end of the mast.

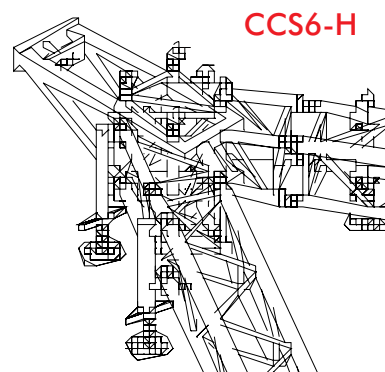

figure 3

**RT-H30V Assembly instructions**

**4** Build the mast as shown in figure 4. Other lengths may be used. Connect the mast to the hinge-parts as shown in figures 5 and 6.

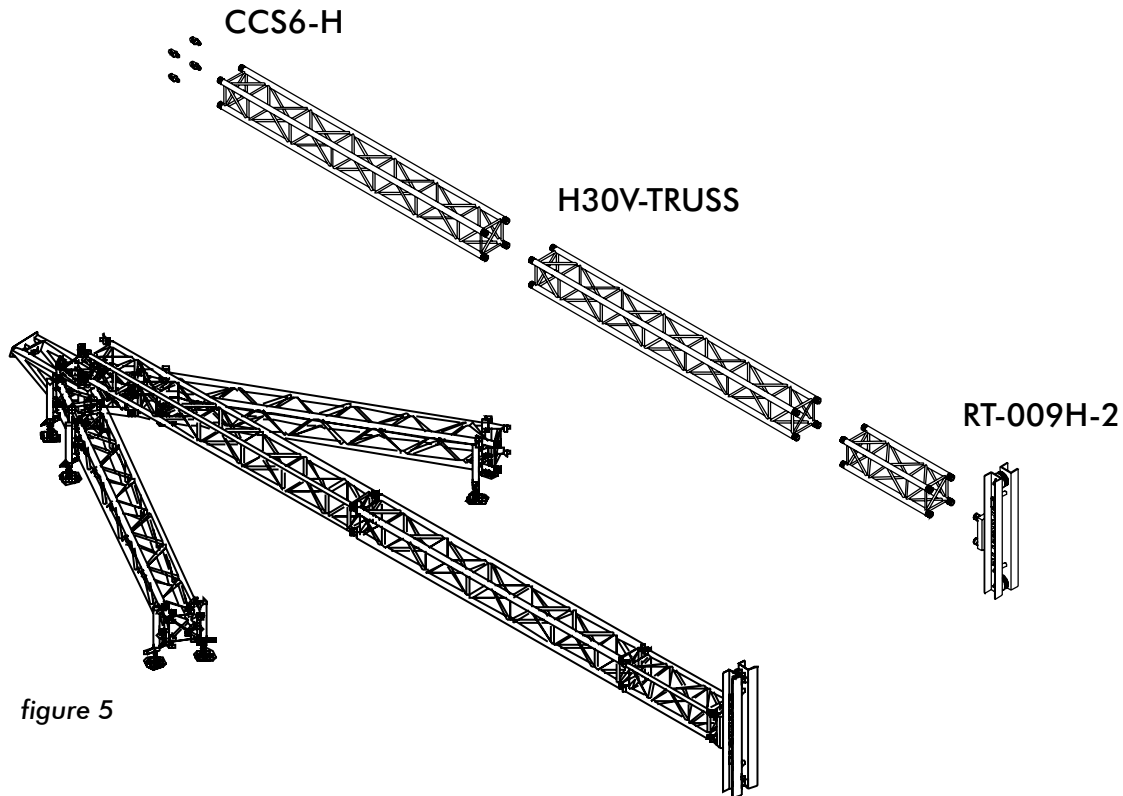

figure 4

figure 5

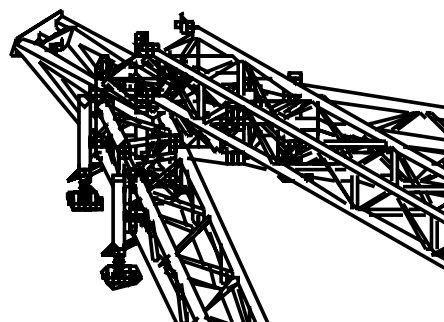

figure 6

**5** Connect the Rigging tower help (RT-H30V-HELP) to the corner section with the two clamps. See figure 7

**Note: If you don't have the rigging tower help, you can skip this step, but you will have to erect the mast by hand. This takes atleast two people and a third person to mount the hinge spigot**

**RT-H30V-HELP**

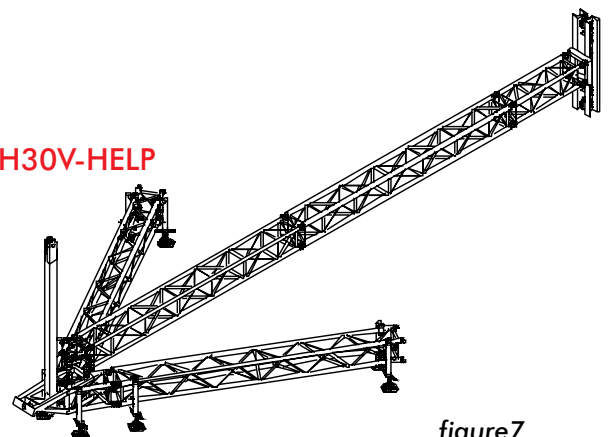

figure 7

**RT-H30V Assembly instructions**

**6** Mount the stabilizer attachment (RT-STAB-H30V-TOP) to the trusses. See figure 8.

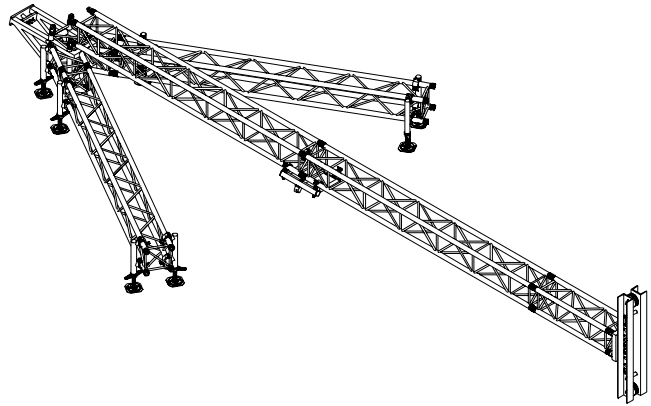

figure 8

**7** Attach the stabilizer tubes (RT-T60-CC298CC). See figure 9.

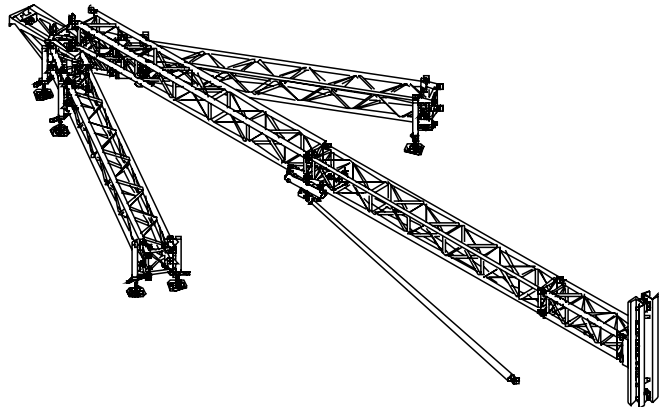

figure 9

**8** Connect the chainhoist to the corner section. Place a roundsling around the mast about 2m from the hinge parts and attach the hook of the hoist chain to the roundsling. See figure 10.

**Note: The rigging tower is not designed to accommodate double reeved chainhoists.**

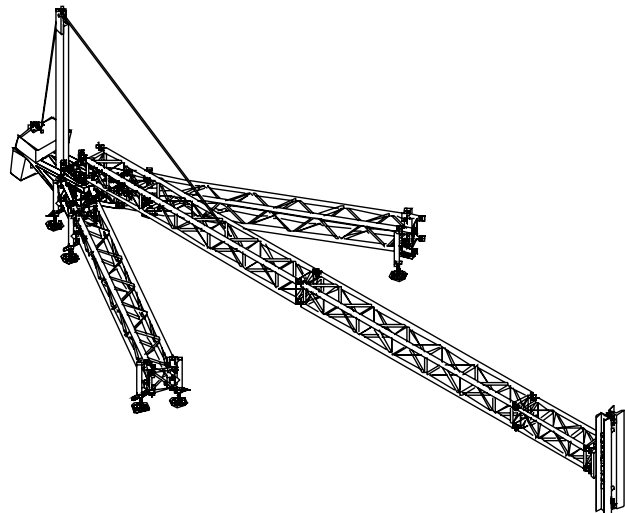

figure 10

**RT-H30V Assembly instructions**

9

**Note: Before lifting the mast, it is easier to put a rope over the pulleys in the topsection so that you can pull the lifting chain over the topsection when the mast is erected.**

Lift the mast with the hoist and mount the hinge spigot from the back. See figure 11.

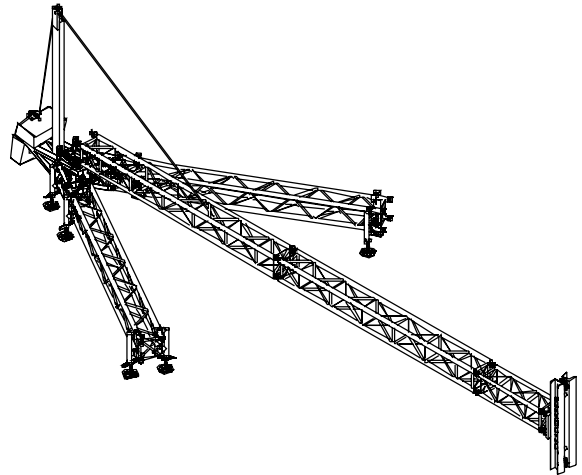

figure 11

10

Mount the stabilizer tubes (RT-T60-CC298CC) by means of the stabilizer attachments (RT-STAB-H30V) to the trusslegs. See figure 12.

**Note: All bolts of the clamps should be tightened with the aid of a torque wrench, the used torque should be no more or less then 50N/m.**

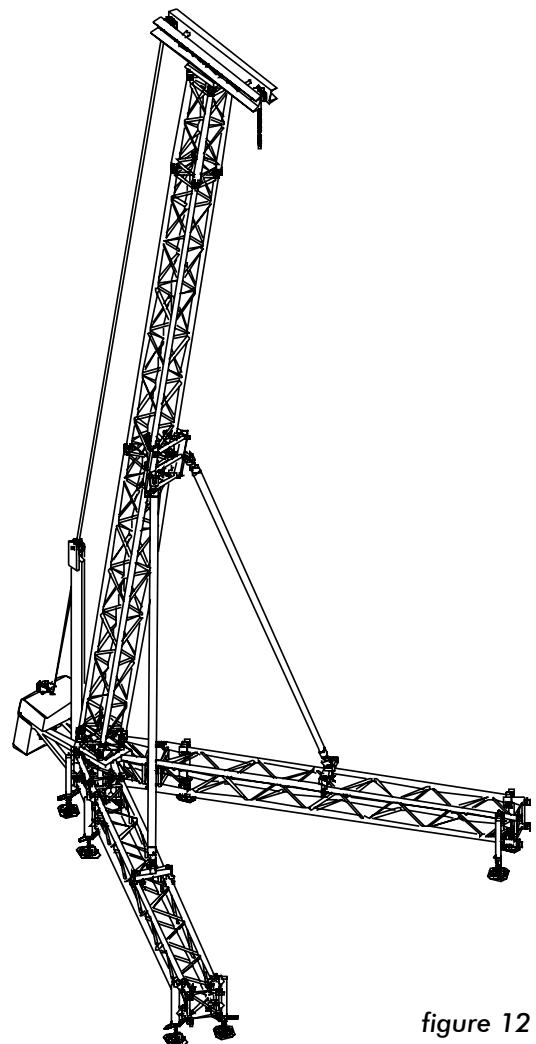

figure 12

**RT-H30V Assembly instructions**

**11** Before the load is raised check the vertical position of the tower and proper surface contact of the screw jack dishes. Adjust the screw jacks if necessary. Determine the weight of the load before lifting.

Apply the prescribed amount of ballast to the legs of the tower.

See figure 13.

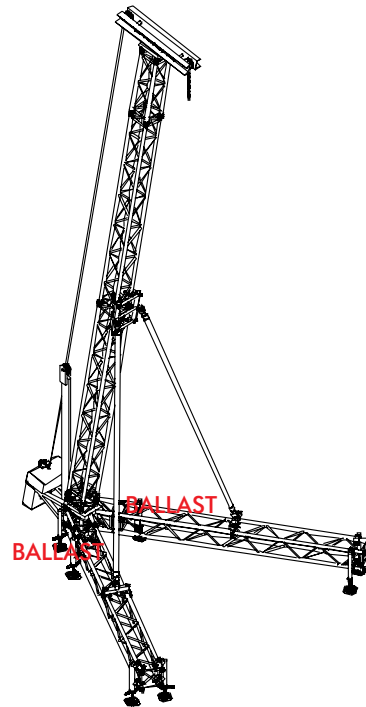

figure 13

**WARNING**

Neglecting the addition of the appropriate amount of ballast and/or not applying part of the guy wires is dangerous. Under influence of wind this can result in failure of the complete structure.

**12** Run the system up to trim height, and secure it in this position by means of a secondary independent support such as a clutch chain or wire rope.

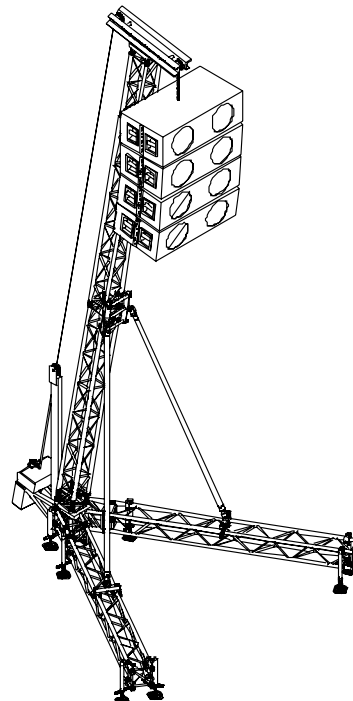
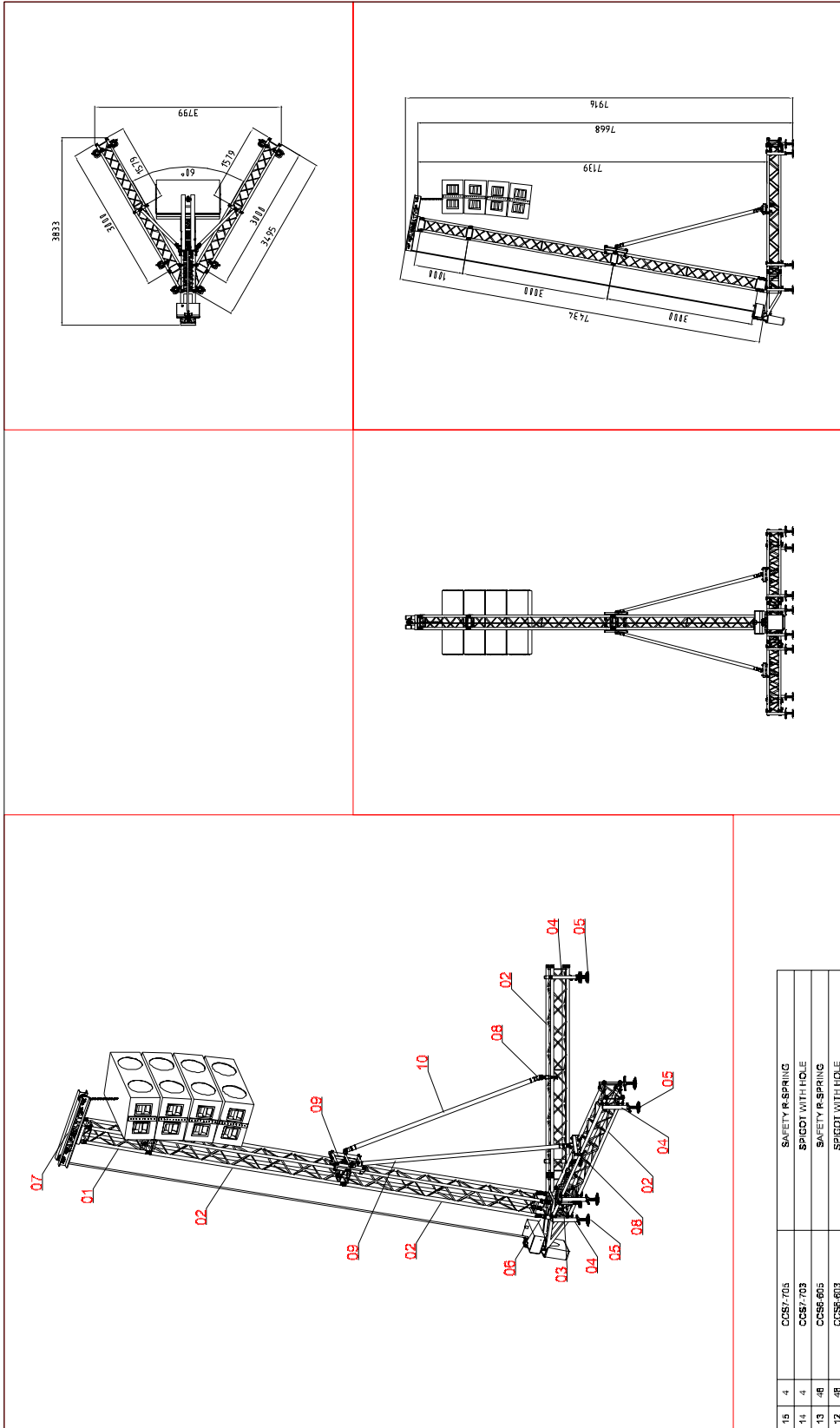

figure 14

**WARNING:**  
**NOT FOLLOWING THE GUIDELINES IN THIS MANUAL  
MAY CAUSE DANGER, PROPERTY DAMAGE,  
INJURIES OR EVEN DEATH.**

**RT-H30V Assembly instructions**

**8. SYSTEM DIMENSIONS**



<p>PROLYTE PRODUCTS ALUMINIUM TRUSSING &amp; STAGING</p> <p><small>De informatie op deze tekening is uitsluitend bestemd voor de gebruiker van het product en is anderszins niet te verspreiden. Het is niet toegestaan te kopiëren, te verspreiden of openbaar te maken.</small></p>	GET: R. BEUKEMA	SCHAAL:	<p><b>RT-H30V-WL0,8T-7m</b></p>
	DATE: 23-03-2005	MAATEENHEID: MMI	
	TEK.NR.:	KLANT:	
	PROJ. RIGGING TOWER	DEALER:	
	BENNING	ORDERNR.:	
ARTIKEL CODE			A3

15	4	CCS7-703	SAFETY R-SPRING
14	4	CCS7-703	SPIGOT WITH HOLE
13	48	CCS6-605	SAFETY R-SPRING
12	48	CCS6-603	SPIGOT WITH HOLE
11	20	CCS6-800	CONICAL COUPLER
10	2	RT-160-CC286CC	STABILIZER TUBE Ø80x6
09	1	RT-17A5-H30V-TOP	STABILIZER ATTACHMENT H30V
08	2	RT-17A5-H30V	STABILIZER ATTACHMENT H30V
07	1	RT-09H-2	TOP LOCK DELAY TOWER H30V
06	4	CCS6-H	HINGE PART SQUARE TRUSS
05	8	ACC-SPIN-LAY/0	LATHIER SPINDEL SHORT
04	8	ACC-SPIN-LAY/30	LATHIER SPINDEL ATTACHMENT H30V
03	1	RT-H30V-CD3	SQUARE H30V 3 WAY CORNER 80°
02	4	H30V-L300	H30V TRUSS LENGHTE 3000mm
01	1	H30V-L400	H30V TRUSS LENGHTE 1000mm
17	18		ONBSCHRIJVING